



Catálogo Técnico

SISTEMA CONSTRUCTIVO TUBEST

TUPEMESA®

¿Quiénes somos?

TUPEMESA®

TUPEMESA es una empresa peruana que cuenta con una de las plantas más modernas y sustentables de Sudamérica, desde donde se fabrica la más variada oferta de productos en acero de alta calidad y se brinda un servicio de excelencia que contribuyen al desarrollo de los diferentes sectores industriales para construir un Perú de acero.





Descripción

TUBEST®, es un sistema constructivo innovador, orientado a soluciones de naves industriales y otras estructuras de gran envergadura, se obtiene a partir de dos pares de perfiles componentes, denominados Sigma y Ohm. El diseño de la sección tubular, permite una mejor eficiencia estructural y gran estética, logrando estructuras más livianas y de gran valor arquitectónico.

■ Ventajas

- Solución higiénica, estética y de gran eficiencia estructural.
- Permite construir galpones de grandes luces y alturas.
- Permite ahorrar importantes costos en faenas y mano de obra.
- Construir velozmente con un mayor estándar de calidad y diseño.

■ Usos

Almacenes y talleres / Hangares y plantas industriales / Polideportivos de colegios / Centros comerciales y deportivos / Centros de distribución / Frigoríficos y supermercados / Campamentos mineros / Patios cubiertos, entre otros.

PROYECTOS



Planta Cementos Pacasmayo-Piura



Planta Sika- Lima



Polideportivo del Colegio Alfonso Ugarte-Lima



Planta de Procesos de Ica Fruta- Ica



Campamento Minera Volcan- Arequipa



Puerto Fluvial Yurimaguas- Loreto

INFORMACIÓN TÉCNICA



Materia prima

Acero ASTM A36

Esfuerzo de Fluencia: 2530 kgf/cm²

Esfuerzo de Ruptura: 4080 kgf/cm²

Alargamiento: 25%

Diseño

Según AISI STANDARD: "NORTH AMERICAN SPECIFICATION FOR THE DESIGN OF COLD FORMED STEEL STRUCTURAL MEMBERS"

Perfil Sigma

Espesores nominales: 3-4 mm

Largos: 6 m y otros según proyecto

Soldadura: Arco Manual, MIG

Perfil Ohm

Espesores nominales: 3-4-5-6 mm

Largos: 6-7-8 m y otros según proyecto

Soldadura: Arco Manual, MIG



SECCIÓN: PERFIL SIGMA

Especificaciones Generales

Largo estándar : 6.00, 7.00 y 8.00 m. y otras medidas

Extremos : Lisos de máquina.

Calidades normales : ASTM A36

Perfil	Dimensiones nominales			Peso P	Área A	Propiedades						
	P. Comp.	Alt.	Esp.			EJE X-X			EJE Y-Y			
	H	Y	e _s			I	W	i	x	I	W	i
mm	mm	mm	kgf/m	cm ²	cm ⁴	cm ³	cm	cm	cm ⁴	cm ³	cm	
Sigma 250x3	250	120	3	3,08	3,93	51,1	8,53	3,61	0,46	1,01	0,73	0,51
Sigma 300x3	300	170	3	4,68	5,97	143	16,8	4,90	0,82	3,35	1,86	0,75
Sigma 350x3	350	220	3	5,86	7,47	301	27,4	6,35	0,69	3,90	2,01	0,72
Sigma 400x3	400	270	3	7,04	8,97	546	40,4	7,81	0,60	4,27	2,11	0,69
Sigma 450x3	450	320	3	8,22	10,5	897	56,0	9,26	0,53	4,54	2,17	0,66
Sigma 500x3	500	370	3	9,39	12,0	1370	74,1	10,7	0,48	4,74	2,22	0,63
Sigma 550x3	550	420	3	10,51	13,5	1990	94,7	12,1	0,46	5,54	2,40	0,64
Sigma 600x3	600	470	3	11,7	15,0	2760	118	13,6	0,268	4,95	2,24	0,575
Sigma 650x3	650	520	3	12,9	16,5	3720	143	15,0	0,244	5,05	2,26	0,554
Sigma 700x3	700	570	3	14,1	18,0	4880	171	16,5	0,223	5,13	2,28	0,534
Sigma 750x3	750	620	3	15,3	19,5	6260	202	17,9	0,206	5,20	2,29	0,517
Sigma 750x4	750	620	4	20,4	25,9	8320	268	17,9	0,212	7,21	3,08	0,527
Sigma 800x3	800	670	3	16,5	21,0	7870	235	19,4	0,191	5,26	2,30	0,501
Sigma 800x4	800	670	4	21,9	27,9	10500	312	19,4	0,197	7,29	3,10	0,511

□ Productos de fabricación local en stock.

Todos los perfiles Sigma se pueden fabricar en 4 mm de espesor.

*Otras longitudes a pedido.

Sección Perfil Sigma H x es x Kgf/mt

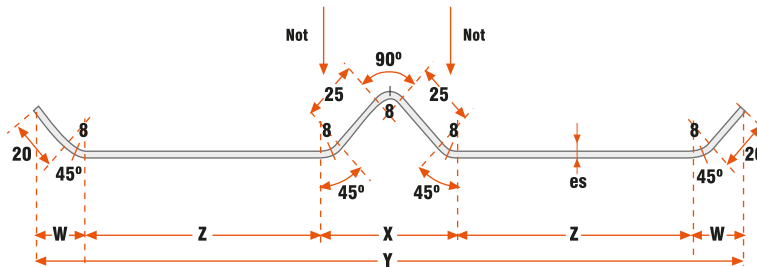

Nota: Para Sigma 550 tramo recto considerar atisador de 27

Sección Perfil Sigma Especial 250 x es x Kgf/m

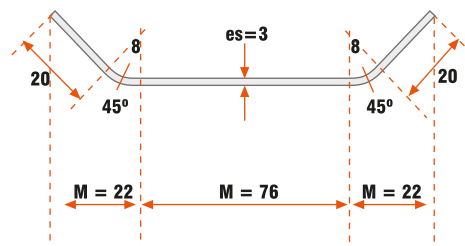

SECCIÓN: PERFIL OHM

Especificaciones Generales

Largo estándar : 6.00, 7.00 y 8.00 m. y otras medidas

Extremos : Lisos de máquina.

Calidades normales : ASTM A36

Perfil	Dimensiones nominales		Peso	Área	Propiedades						
	Ancho	Esp.			EJE X-X			EJE Y-Y			
	B	e ₀	P	A	I	W	i	x	I	W	i
	mm	mm	kgf/m	cm ²	cm ⁴	cm ³	cm	cm	cm ⁴	cm ³	cm
Ohm 150x3	150	3	7,97	10,2	90,6	15,2	2,99	2,79	334	44,6	5,74
Ohm 150x4	150	4	10,56	13,4	119	20,0	2,97	2,96	433	57,7	5,67
Ohm 150x5	150	5	13,1	16,7	146	24,8	2,96	526	70,2	5,61	2,76
Ohm 200x3	200	3	9,15	11,7	101	15,9	2,94	2,43	672	67,2	7,59
Ohm 200x4	200	4	12,13	15,4	132	21,0	2,93	2,60	876	87,6	7,53
Ohm 200x5	200	5	15,08	19,2	163	26,0	2,91	2,65	1070	107	7,47
Ohm 200x6	200	6	18,0	22,9	192	30,9	2,89	2,69	1260	126	7,41
Ohm 225x3	225	3	9,74	12,4	105	16,3	2,91	894	79,5	8,49	2,27
Ohm 225x4	225	4	12,91	16,4	138	21,4	2,89	2,46	1170	104	8,43
Ohm 225x5	225	5	16,06	20,5	169	26,4	2,88	2,50	1430	127	8,37
Ohm 225x6	225	6	19,17	24,4	200	31,4	2,86	2,54	1690	150	8,31
Ohm 250x3	250	3	10,3	13,2	109	16,5	2,88	1160	92,5	9,37	2,14
Ohm 250x4	250	4	13,7	17,5	143	21,7	2,86	1510	121	9,31	2,13
Ohm 250x5	250	5	17,0	21,7	175	26,8	2,84	1860	149	9,25	2,12
Ohm 250x6	250	6	20,3	25,9	206	31,8	2,82	2190	175	9,19	2,11

□ Productos de fabricación local en stock.

▒ Productos a pedido.

Se puede fabricar Ohm con B hasta 400 mm.

*Otras longitudes a pedido.

Sección Perfil Ohm

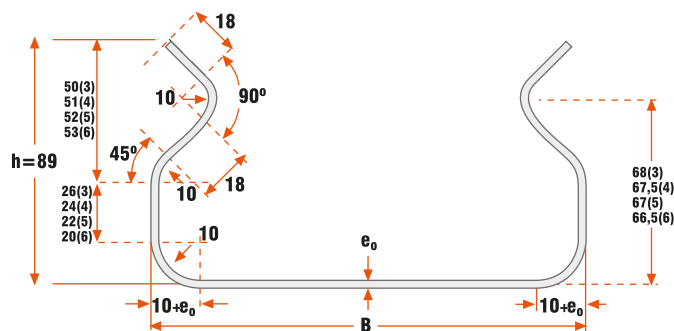

SERIE DE PERFILES TUBEST CONFORMADO (SOLDADOS)

Especificaciones Generales

Largo estándar : De 1.00 a 12.00 m.

Extremos : Lisos de máquina.

Calidades normales : ASTM A36

Perfil	Dimensiones nominales				Peso P kgf/m	Área A cm ²	Propiedades					
	H mm	B mm	eo mm	es mm			EJE X-X			EJE Y-Y		
							I cm ⁴	W cm ³	i cm	I cm ⁴	W cm ³	i cm
Tubest [250x150x4x3]	250	150	4	3	27,3	34,8	2790	223	8,96	1260	168	6,01
Tubest [250x200x4x3]	250	200	4	3	30,4	38,8	3399	271	9,36	2470	247	7,98
Tubest [250x200x5x3]	250	200	5	3	36,3	46,3	4160	333	9,48	2860	286	7,86
Tubest [250x200x6x3]	250	200	6	3	42,2	53,7	4900	392	9,55	3240	324	7,76
Tubest [250x225x4x3]	250	225	4	3	32,0	40,8	3690	296	9,52	3250	289	8,94
Tubest [250x225x5x3]	250	225	5	3	38,3	48,8	4530	363	9,64	3780	336	8,81
Tubest [250x225x6x3]	250	225	6	3	44,5	56,7	5350	428	9,71	4290	381	8,70
Tubest [300x150x3x3]	300	150	3	3	25,4	32,3	3432	229	10,3	1204	160	6,11
Tubest [300x150x4x3]	300	150	4	3	30,5	38,8	4420	295	10,7	1400	187	6,01
Tubest [300x200x3x3]	300	200	3	3	27,7	35,3	4094	273	10,8	2351	235	8,17
Tubest [300x200x4x3]	300	200	4	3	33,6	42,8	5300	353	11,1	2760	276	8,03
Tubest [300x200x5x3]	300	200	5	3	39,5	50,3	6470	432	11,3	3160	316	7,92
Tubest [300x200x6x3]	300	200	6	3	45,4	57,8	7620	508	11,5	3530	353	7,82
Tubest [300x225x4x3]	300	225	4	3	35,2	44,8	5740	382	11,3	3640	324	9,01
Tubest [300x225x5x3]	300	225	5	3	41,5	52,8	7020	468	11,5	4170	371	8,88
Tubest [300x225x6x3]	300	225	6	3	47,7	60,8	8270	551	11,7	4680	416	8,77
Tubest [350x150x3x3]	350	150	3	3	27,7	35,2	5092	291	12,0	1369	182	6,23
Tubest [350x150x4x3]	350	150	4	3	32,8	41,8	6530	373	12,5	1570	209	6,12
Tubest [350x200x3x3]	350	200	3	3	30,0	38,2	5995	343	12,5	2646	265	8,32
Tubest [350x200x4x3]	350	200	4	3	36,0	45,8	7720	441	13,0	3060	306	8,17
Tubest [350x200x5x3]	350	200	5	3	41,9	53,3	9400	537	13,3	3450	345	8,04
Tubest [350x200x6x3]	350	200	6	3	47,7	60,8	11000	631	13,5	3820	382	7,93
Tubest [350x225x4x3]	350	225	4	3	37,6	47,8	8320	476	13,2	4010	357	9,16
Tubest [350x225x5x3]	350	225	5	3	43,8	55,8	10100	580	13,5	4540	404	9,02
Tubest [350x225x6x3]	350	225	6	3	50,1	63,8	11900	682	13,7	5050	449	8,90
Tubest [400x150x3x3]	400	150	3	3	30,0	38,2	7187	359	13,7	1531	204	6,33
Tubest [400x150x4x3]	400	150	4	3	35,2	44,8	9140	457	14,3	1730	231	6,21
Tubest [400x200x3x3]	400	200	3	3	32,4	41,2	8369	418	14,2	2937	294	8,44
Tubest [400x200x4x3]	400	200	4	3	38,3	48,8	10700	535	14,8	3350	335	8,28
Tubest [400x200x5x3]	400	200	5	3	44,2	56,3	13000	649	15,2	3740	374	8,15
Tubest [400x200x6x3]	400	200	6	3	50,1	63,8	15200	761	15,4	4110	411	8,03
Tubest [400x225x4x3]	400	225	4	3	39,9	50,8	11500	575	15,0	4380	389	9,28
Tubest [400x225x5x3]	400	225	5	3	46,2	58,8	14000	698	15,4	4910	437	9,14
Tubest [400x225x6x3]	400	225	6	3	52,4	66,8	16400	819	15,7	5420	482	9,01
Tubest [450x150x3x3]	450	150	3	3	32,4	41,2	9747	433	15,4	1693	226	6,41
Tubest [450x150x4x3]	450	150	4	3	37,5	47,8	12300	547	16,0	1890	252	6,29
Tubest [450x200x3x3]	450	200	3	3	34,7	44,2	11246	500	15,9	3228	323	8,54
Tubest [450x200x4x3]	450	200	4	3	40,7	51,8	14300	635	16,6	3640	364	8,38
Tubest [450x200x5x3]	450	200	5	3	46,6	59,3	17300	767	17,1	4030	403	8,24
Tubest [450x200x6x3]	450	200	6	3	52,4	66,8	20200	897	17,4	4400	440	8,12
Tubest [450x225x4x3]	450	225	4	3	42,3	53,8	15300	679	16,8	4750	422	9,39
Tubest [450x225x5x3]	450	225	5	3	48,6	61,8	18500	822	17,3	5280	469	9,24
Tubest [450x225x6x3]	450	225	6	3	54,8	69,8	21700	962	17,6	5790	515	9,11
Tubest [500x150x3x3]	500	150	3	3	34,7	44,2	12810	512	17,0	1855	247	6,48
Tubest [500x150x4x3]	500	150	4	3	39,9	50,8	16000	642	17,8	2050	274	6,36
Tubest [500x200x3x3]	500	200	3	3	37,1	47,2	14662	586	17,6	3519	352	8,63
Tubest [500x200x4x3]	500	200	4	3	43,0	54,8	18500	740	18,4	3930	393	8,46
Tubest [500x200x5x3]	500	200	5	3	48,9	62,3	22300	891	18,9	4320	432	8,32
Tubest [500x200x6x3]	500	200	6	3	54,8	69,8	26000	1038	19,3	4700	470	8,20
Tubest [500x225x4x3]	500	225	4	3	44,6	56,8	19700	789	18,6	5120	455	9,49
Tubest [500x225x5x3]	500	225	5	3	50,9	64,8	23800	952	19,2	5650	502	9,33
Tubest [500x225x6x3]	500	225	6	3	57,1	72,8	27800	1111	19,5	6160	547	9,20
Tubest [550x150x3x3]	550	150	3	3	37,1	47,3	16412	597	18,6	2014	269	6,53
Tubest [550x150x4x3]	550	150	4	3	42,3	53,9	20400	742	19,5	2220	295	6,41
Tubest [550x200x3x3]	550	200	3	3	39,5	50,3	18656	678	19,3	3808	381	8,70
Tubest [550x200x4x3]	550	200	4	3	45,5	57,9	23400	851	20,1	4220	422	8,54
Tubest [550x200x5x3]	550	200	5	3	51,4	65,4	28000	1019	20,7	4610	461	8,40
Tubest [550x200x6x3]	550	200	6	3	57,2	72,9	32600	1185	21,2	4990	499	8,27
Tubest [550x225x3x3]	550	225	3	3	40,6	51,7	19800	720	19,6	4940	439	9,77
Tubest [550x225x4x3]	550	225	4	3	47,0	59,9	24900	905	20,4	5490	488	9,58
Tubest [550x225x5x3]	550	225	5	3	53,3	67,9	29900	1087	21,0	6020	535	9,42
Tubest [550x225x6x3]	550	225	6	3	59,5	75,9	34800	1266	21,4	6530	581	9,28

SERIE DE PERFILES TUBEST CONFORMADO (SOLDADOS)

Perfil	Dimensiones nominales				Peso	Área	Propiedades					
	H	B	eo	es			EJE X-X			EJE Y-Y		
					P	A	I	W	i	I	W	i
mm	mm	mm	mm	kgf/m	cm ²	cm ⁴	cm ³	cm	cm ⁴	cm ³	cm	
Tubest(550x225x6x4)	550	225	6	4	66,5	84,7	36100	1310	20,6	7530	669	9,43
Tubest(550x250x3x3)	550	250	3	3	41,8	53,2	20900	760	19,8	6230	499	10,8
Tubest(550x250x4x3)	550	250	4	3	48,5	61,8	26400	959	20,7	6950	556	10,6
Tubest(550x250x5x3)	550	250	5	3	55,2	70,3	31700	1150	21,2	7640	611	10,4
Tubest(550x250x6x3)	550	250	6	3	61,8	78,8	37000	1350	21,7	8300	664	10,3
Tubest(550x250x6x4)	550	250	6	4	68,8	87,7	38300	1390	20,9	9550	764	10,4
Tubest(600x150x3x3)	600	150	3	3	39,4	50,2	20600	687	20,3	2180	291	6,59
Tubest(600x150x4x3)	600	150	4	3	44,6	56,8	25400	848	21,2	2380	317	6,47
Tubest(600x150x5x3)	600	150	5	3	49,7	63,3	30200	1010	21,8	2560	342	6,36
Tubest(600x150x6x3)	600	150	6	3	54,8	69,8	34800	1160	22,3	2740	365	6,26
Tubest(600x150x6x4)	600	150	6	4	62,6	79,7	36600	1220	21,4	3210	428	6,34
Tubest(600x200x3x3)	600	200	3	3	41,8	53,2	23300	776	20,9	4100	410	8,78
Tubest(600x200x4x3)	600	200	4	3	47,8	60,8	29000	966	21,8	4510	451	8,61
Tubest(600x200x5x3)	600	200	5	3	53,7	68,3	34600	1150	22,5	4900	490	8,47
Tubest(600x200x6x3)	600	200	6	3	59,5	75,8	40100	1340	23,0	5280	528	8,34
Tubest(600x200x6x4)	600	200	6	4	67,3	85,7	41900	1400	22,1	6150	615	8,47
Tubest(600x225x3x3)	600	225	3	3	43,0	54,7	24600	820	21,2	5310	472	9,85
Tubest(600x225x4x3)	600	225	4	3	49,3	62,8	30800	1030	22,1	5860	521	9,66
Tubest(600x225x5x3)	600	225	5	3	55,6	70,8	36800	1230	22,8	6390	568	9,50
Tubest(600x225x6x3)	600	225	6	3	61,8	78,8	42800	1430	23,3	6890	613	9,36
Tubest(600x225x6x4)	600	225	6	4	69,6	88,7	44600	1490	22,4	8010	712	9,51
Tubest(600x250x3x3)	600	250	3	3	44,1	56,2	25900	865	21,5	6690	535	10,9
Tubest(600x250x4x3)	600	250	4	3	50,9	64,8	32500	1080	22,4	7410	592	10,7
Tubest(600x250x5x3)	600	250	5	3	57,6	73,3	39000	1300	23,1	8100	648	10,5
Tubest(600x250x6x3)	600	250	6	3	64,2	81,8	45400	1510	23,6	8760	701	10,4
Tubest(600x250x6x4)	600	250	6	4	72,0	91,7	47200	1570	22,7	10200	813	10,5
Tubest(650x150x3x3)	650	150	3	3	41,8	53,2	25400	782	21,8	2340	312	6,63
Tubest(650x150x4x3)	650	150	4	3	47,0	59,8	31200	959	22,8	2540	339	6,51
Tubest(650x150x5x3)	650	150	5	3	52,1	66,3	36800	1130	23,6	2730	363	6,41
Tubest(650x150x6x3)	650	150	6	3	57,1	72,8	42400	1300	24,1	2900	387	6,31
Tubest(650x150x6x4)	650	150	6	4	65,7	83,7	44800	1380	23,1	3420	456	6,39
Tubest(650x200x3x3)	650	200	3	4	44,1	56,2	28500	878	22,5	4390	439	8,84
Tubest(650x200x4x3)	650	200	4	3	50,1	63,8	35300	1090	23,5	4800	480	8,67
Tubest(650x200x5x3)	650	200	5	3	56,0	71,3	42000	1290	24,3	5190	519	8,53
Tubest(650x200x6x3)	650	200	6	3	61,8	78,8	48600	1490	24,8	5570	557	8,41
Tubest(650x200x6x4)	650	200	6	4	70,4	89,7	51000	1570	23,9	6530	653	8,53
Tubest(650x225x3x3)	650	225	3	3	45,3	57,7	30100	926	22,8	5680	505	9,92
Tubest(650x225x4x3)	650	225	4	3	51,7	65,8	37400	1150	23,8	6230	554	9,73
Tubest(650x225x5x3)	650	225	5	3	58,0	73,8	44600	1370	24,6	6760	601	9,57
Tubest(650x225x6x3)	650	225	6	3	64,2	81,8	51700	1590	25,1	7260	646	9,43
Tubest(650x225x6x4)	650	225	6	4	72,8	92,7	54100	1670	24,2	8500	756	9,58
Tubest(650x250x3x3)	650	250	3	3	46,5	59,2	31700	975	23,1	7150	572	11,0
Tubest(650x250x4x3)	650	250	4	3	53,3	67,8	39500	1220	24,1	7860	629	10,8
Tubest(650x250x5x3)	650	250	5	3	59,9	76,3	47200	1450	24,9	8550	684	10,6
Tubest(650x250x6x3)	650	250	6	3	66,5	84,8	54800	1690	25,4	9220	737	10,4
Tubest(650x250x6x4)	650	250	6	4	75,1	95,7	57200	1760	24,5	10800	861	10,6
Tubest(700x150x3x3)	700	150	3	3	44,1	56,2	30800	881	23,4	2500	334	6,67
Tubest(700x150x4x3)	700	150	4	3	49,3	62,8	37600	1070	24,5	2700	360	6,56
Tubest(700x150x5x3)	700	150	5	3	54,4	69,3	44300	1260	25,3	2890	385	6,45
Tubest(700x150x6x3)	700	150	6	3	59,5	75,8	50800	1450	25,9	3060	408	6,36
Tubest(700x150x6x4)	700	150	6	4	68,8	87,7	54000	1540	24,8	3630	484	6,44
Tubest(700x200x3x3)	700	200	3	3	46,5	59,2	34500	985	24,1	4680	468	8,89
Tubest(700x200x4x3)	700	200	4	3	52,5	66,8	42500	1210	25,2	5090	509	8,73

Productos de fabricación local en stock.
 Productos a pedido.
 Para mayores a 12.00 m serán traslapadas.
 Para medidas especiales se harían empalmes.

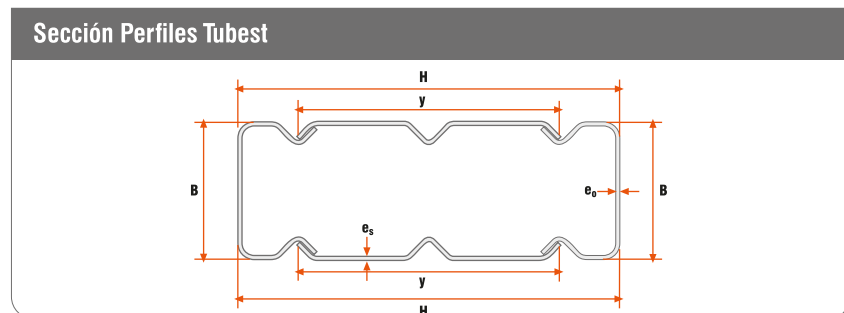

SERIE DE PERFILES TUBEST CONFORMADO (SOLDADOS)

Perfil	Dimensiones nominales				Peso P kgf/m	Área A cm ²	Propiedades					
	H mm	B mm	eo mm	es mm			EJE X-X			EJE Y-Y		
							I cm ⁴	W cm ³	i cm	I cm ⁴	W cm ³	i cm
Tubest(700x200x5x3)	700	200	5	3	58,4	74,3	50300	1440	26,0	5480	548	8,59
Tubest(700x200x6x3)	700	200	6	3	64,2	81,8	58000	1660	26,6	5860	586	8,46
Tubest(700x200x6x4)	700	200	6	4	73,6	93,7	61200	1750	25,6	6920	692	8,59
Tubest(700x225x3x3)	700	225	3	3	47,7	60,7	36300	1040	24,5	6050	538	9,98
Tubest(700x225x4x3)	700	225	4	3	54,0	68,8	44900	1280	25,5	6600	587	9,79
Tubest(700x225x5x3)	700	225	5	3	60,3	76,8	53300	1520	26,3	7130	634	9,63
Tubest(700x225x6x3)	700	225	6	3	66,5	84,8	61600	1760	27,0	7630	679	9,49
Tubest(700x225x6x4)	700	225	6	4	75,9	96,7	64800	1850	25,9	8990	799	9,64
Tubest(700x250x3x3)	700	250	3	3	48,9	62,2	38100	1090	24,8	7600	608	11,1
Tubest(700x250x4x3)	700	250	4	3	55,6	70,8	47300	1350	25,8	8320	666	10,8
Tubest(700x250x5x3)	700	250	5	3	62,3	79,3	56300	1610	26,6	9010	721	10,7
Tubest(700x250x6x3)	700	250	6	3	68,9	87,8	65200	1860	27,3	9680	774	10,5
Tubest(700x250x6x4)	700	250	6	4	78,3	99,7	68500	1960	26,2	11400	910	10,7
Tubest(750x150x3x3)	750	150	3	3	46,5	59,2	37000	986	25,0	2670	355	6,71
Tubest(750x150x4x3)	750	150	4	3	51,7	65,8	44900	1200	26,1	2860	382	6,59
Tubest(750x150x5x3)	750	150	5	3	56,8	72,3	52600	1400	27,0	3050	407	6,49
Tubest(750x150x6x3)	750	150	6	3	61,8	78,8	60200	1600	27,6	3220	430	6,40
Tubest(750x150x6x4)	750	150	6	4	72,0	91,7	64300	1710	26,5	3850	513	6,48
Tubest(750x200x3x3)	750	200	3	3	48,9	62,2	41200	1100	25,7	4970	497	8,94
Tubest(750x200x4x3)	750	200	4	3	54,8	69,8	50400	1340	26,9	5380	538	8,78
Tubest(750x200x5x3)	750	200	5	3	60,7	77,3	59500	1590	27,7	5780	578	8,64
Tubest(750x200x6x3)	750	200	6	3	66,5	84,8	68500	1830	28,4	6150	615	8,52
Tubest(750x200x6x4)	750	200	6	4	76,7	97,7	72600	1940	27,3	7300	730	8,64
Tubest(750x225x3x3)	750	225	3	3	50,0	63,7	43300	1150	26,1	6420	571	10,00
Tubest(750x225x4x3)	750	225	4	3	56,4	71,8	53200	1420	27,2	6970	619	9,85
Tubest(750x225x5x3)	750	225	5	3	62,7	79,8	63000	1680	28,1	7500	666	9,69
Tubest(750x225x6x3)	750	225	6	3	68,9	87,8	72600	1940	28,8	8000	711	9,55
Tubest(750x225x6x4)	750	225	6	4	79,1	101	76700	2050	27,6	9480	843	9,70
Tubest(750x250x3x3)	750	250	3	3	51,2	65,2	45400	1210	26,4	8060	645	11,1
Tubest(750x250x4x3)	750	250	4	3	58,0	73,8	56000	1490	27,5	8780	702	10,9
Tubest(750x250x5x3)	750	250	5	3	64,6	82,3	66500	1770	28,4	9470	758	10,7
Tubest(750x250x6x3)	750	250	6	3	71,3	90,8	76800	2050	29,1	10100	811	10,6
Tubest(750x250x6x4)	750	250	6	4	81,4	104	80900	2160	27,9	12000	958	10,7
Tubest(800x150x3x3)	800	150	3	3	48,9	62,2	43800	1100	26,5	2830	377	6,74
Tubest(800x150x4x3)	800	150	4	3	54,0	68,8	52900	1320	27,7	3030	403	6,63
Tubest(800x150x5x3)	800	150	5	3	59,1	75,3	61800	1540	28,6	3210	428	6,53
Tubest(800x150x6x3)	800	150	6	3	64,2	81,8	70500	1760	29,4	3390	451	6,43
Tubest(800x150x6x4)	800	150	6	4	75,1	95,7	75700	1890	28,1	4060	541	6,51
Tubest(800x200x3x3)	800	200	3	3	51,2	65,2	48600	1220	27,3	5270	527	8,98
Tubest(800x200x4x3)	800	200	4	3	57,2	72,8	59200	1480	28,5	5680	568	8,83
Tubest(800x200x5x3)	800	200	5	3	63,1	80,3	69700	1740	29,4	6070	607	8,69
Tubest(800x200x6x3)	800	200	6	3	68,9	87,8	80000	2000	30,2	6440	644	8,57
Tubest(800x200x6x4)	800	200	6	4	79,8	102	85100	2130	28,9	7680	768	8,69
Tubest(800x225x3x3)	800	225	3	3	52,4	66,7	51000	1270	27,6	6790	603	10,1
Tubest(800x225x4x3)	800	225	4	3	58,7	74,8	62400	1560	28,9	7340	652	9,90
Tubest(800x225x5x3)	800	225	5	3	65,0	82,8	73600	1840	29,8	7870	699	9,74
Tubest(800x225x6x3)	800	225	6	3	71,3	90,8	84700	2120	30,5	8370	744	9,60
Tubest(800x225x6x4)	800	225	6	4	82,2	105	89900	2250	29,3	9970	886	9,76
Tubest(800x250x3x3)	800	250	3	3	53,6	68,2	53400	1330	28,0	8520	682	11,2
Tubest(800x250x4x3)	800	250	4	3	60,3	76,8	65600	1640	29,2	9240	739	11,0
Tubest(800x250x5x3)	800	250	5	3	67,0	85,3	77600	1940	30,1	9930	794	10,8
Tubest(800x250x6x3)	800	250	6	3	73,6	93,8	89400	2240	30,9	10600	847	10,6
Tubest(800x250x6x4)	800	250	6	4	84,5	108	94600	2360	29,6	12600	1010	10,8

□ Productos de fabricación local en stock.

▒ Productos a pedido.

Para mayores a 12.00 m serán traspapadas.

Para medidas especiales se harían empalmes.

Se puede fabricar Tubest con B hasta 400 mm.

SERIE DE PERFILES TUBEST "C" CONFORMADO (SOLDADOS)

Especificaciones Generales

Largo normal : De 1.00 a 6.00 m.

Extremos : Lisos de máquina.

Cualidades normales : ASTM A36

Perfil	Dimensiones			Peso P kgf/m	Área A cm ²	Eje X-X			Eje Y-Y		
	H	B	e			I	W	i	I	W	i
	mm	mm	mm			cm ⁴	cm ³	cm	cm ⁴	cm ³	cm
Tubest C 200 X 100 X 2	200	100	2	9,99	12,7	657	65,7	7,18	201	40,2	3,97
Tubest C 200 X 100 X 3	200	100	3	14,8	18,8	951	95,1	7,11	292	58,3	3,94
Tubest C 200 X 150 X 2	200	150	2	11,6	14,7	853	85,3	7,61	515	68,7	5,91
Tubest C 200 X 150 X 3	200	150	3	17,1	21,8	1242	124	7,55	754	101	5,88
Tubest C 250 X 100 X 2	250	100	2	11,6	14,7	1134	90,7	8,77	249	49,8	4,11
Tubest C 250 X 100 X 3	250	100	3	17,1	21,8	1649	132	8,70	362	72,4	4,07
Tubest C 250 X 150 X 2	250	150	2	13,1	16,7	1441	115	9,28	625	83,3	6,11
Tubest C 250 X 150 X 3	250	150	3	19,5	24,8	2107	169	9,21	917	122	6,08
Tubest C 300 X 100 X 2	300	100	2	13,1	16,7	1786	119	10,3	297	59,4	4,21
Tubest C 300 X 100 X 3	300	100	3	19,5	24,8	2607	174	10,2	433	86,6	4,18
Tubest C 300 X 100 X 4	300	100	4	25,7	32,7	3381	225	10,2	560	112	4,14
Tubest C 300 X 150 X 2	300	150	2	14,7	18,7	2230	149	10,9	734	98	6,26
Tubest C 300 X 150 X 3	300	150	3	21,8	27,8	3269	218	10,8	1079	144	6,23
Tubest C 300 X 150 X 4	300	150	4	28,8	36,7	4257	284	10,8	1408	188	6,19
Tubest C 350 X 100 X 2	350	100	2	14,7	18,7	2639	151	11,9	345	69,0	4,29
Tubest C 350 X 100 X 3	350	100	3	21,8	27,8	3862	221	11,8	503	101	4,25
Tubest C 350 X 100 X 4	350	100	4	28,8	36,7	5021	287	11,7	652	130	4,21
Tubest C 350 X 150 X 2	350	150	2	16,3	20,8	3246	185	12,5	838	112	6,34
Tubest C 350 X 150 X 3	350	150	3	24,2	30,9	4766	272	12,4	1234	165	6,32
Tubest C 350 X 150 X 4	350	150	4	32,0	40,8	6220	355	12,3	1618	216	6,30

Productos de fabricación local.

Productos a pedido.

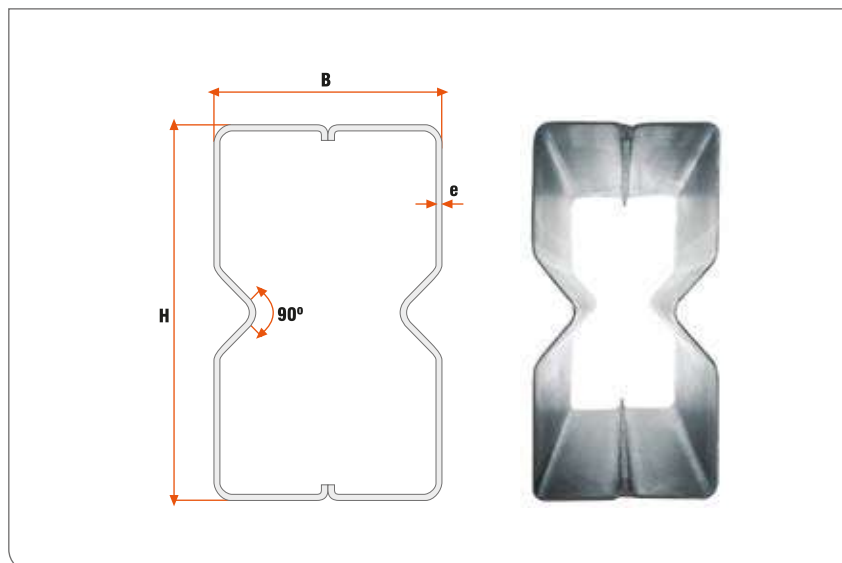

SERIE DE PERFILES TUBEST "Z" (TELESCÓPICA)

Especificaciones Generales

: De 3.00 a 12.00 m.

: Lisos de máquina.

Cualidades normales : ASTM A36

	Dimensiones nominales						Peso	Área	Propiedades							
									Eje X-X				Eje Y-Y			
	A	B ₁	B ₂	C	e	R			P	A	I	W	i	x	l	W
m	mm	mm	mm	mm	mm	mm	kg/m	cm ²	cm ⁴	cm ³	cm	cm	cm ⁴	cm ³	cm	cm
	100	50	45	15	2,0	3,0	3,42	4,35	72,5	13,9	4,08	5,82	28,3	4,86	2,55	5,21
	100	50	45	15	2,5	3,0	4,22	5,37	89,0	17,0	4,07	5,79	34,4	5,93	2,53	5,24
	100	50	45	15	3,0	3,0	5,04	6,42	106	20,1	4,07	5,77	40,3	6,98	2,51	5,27
	125	50	45	15	2,0	3,0	3,81	4,85	121	18,6	4,99	5,83	28,3	4,85	2,41	6,48
	125	50	45	15	2,5	3,0	4,71	6,00	148	22,8	4,97	5,81	34,4	5,92	2,39	6,51
	125	50	45	15	3,0	3,0	5,62	7,17	177	27,1	4,97	5,78	40,3	6,97	2,37	6,53
	150	50	45	15	2,0	3,0	4,20	5,35	184	23,8	5,86	5,85	28,3	4,84	2,30	7,74
	150	50	45	15	2,5	3,0	5,20	6,62	226	29,2	5,85	5,82	34,4	5,91	2,28	7,77
	150	50	45	15	3,0	3,0	6,21	7,92	270	34,6	5,84	5,79	40,3	6,95	2,26	7,79
	175	75	70	20	2,0	3,0	5,54	7,05	352	39,2	7,07	8,68	95,4	11,0	3,68	8,97
	175	75	70	20	2,5	3,0	6,87	8,75	435	48,3	7,05	8,66	117	13,5	3,66	9,00
	175	75	70	20	3,0	3,0	8,22	10,5	520	57,6	7,05	8,63	138	16,0	3,63	9,03
	200	75	70	20	2,0	3,0	5,93	7,55	478	46,7	7,96	8,69	95,4	11,0	3,55	10,2
	200	75	70	20	2,5	3,0	7,36	9,37	591	57,6	7,94	8,67	117	13,5	3,53	10,3
	200	75	70	20	3,0	3,0	8,80	11,2	706	68,6	7,93	8,64	138	16,0	3,51	10,3
	250	75	70	20	2,0	3,0	6,71	8,55	802	62,9	9,70	8,49	95,6	11,26	3,34	12,75
	250	75	70	20	2,5	3,0	8,37	10,66	999	78,2	9,70	8,48	118	13,87	3,32	12,77
	250	75	70	20	3,0	3,0	10,01	12,76	1193	93,2	9,70	8,48	139	16,40	3,30	12,80

Productos de fabricación local.
Consultar stock.

Sección Perfil Tubest Z

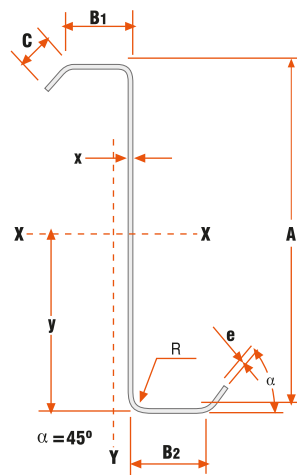

PERFIL "Z" 90°

Especificaciones Generales

Largo normal : De 3.00 a 12.00 m.

Extremos : Lisos de máquina.

Cualidades normales : ASTM A36

Dimensiones nominales						Peso teórico	Desarrollo
A	B	C	B1	B2	e		
Pulg.	Pulg.	Pulg.	mm	mm	mm	kgf/m	mm
4"	2"	3/4"	2	47,8	53,8	3,58	228
			2,5	47,8	53,8	4,41	225
			3	47,8	53,8	5,22	222
6"	2"	3/4"	2	47,8	53,8	4,38	279
			2,5	47,8	53,8	5,41	276
			3	47,8	53,8	6,41	272
8"	3"	3/4"	2	73,2	79,2	5,97	381
			2,5	73,2	79,2	7,40	377
			3	73,2	79,2	8,81	374
10"	3"	3/4"	2	73,2	79,2	6,77	431
			2,5	73,2	79,2	8,40	428
			3	73,2	79,2	10,00	425
12"	3"	3/4"	2	73,2	79,2	7,55	481
			2,5	73,2	79,2	9,38	478
			3	73,2	79,2	11,18	475

☐ Productos de fabricación local.

Sección Perfil Tubest Z

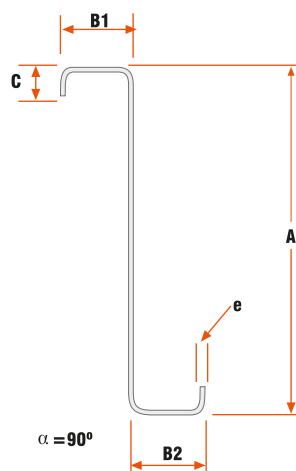

CANAL "C"- COSTANERA

Especificaciones Generales	
Largo normal	: 6.00, 7.00, 8.00, 9.00 y 10.00 m.
Extremos	: Lisos de máquina.
Cualidades normales	: ASTM A36
Recubrimiento	: Negro

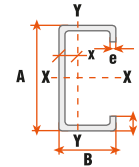

Dimensiones nominales			Peso teórico P	Área A	Propiedades					
B	C	e			Eje X-X			Eje Y-Y		
Pulg.	Pulg.	mm	kgf/m	cm ²	I cm ⁴	W cm ³	X cm	I cm ⁴	W cm ³	Y cm
2"	3/4"	2	3,58	4,56	74,51	14,67	4,041	17,31	5,38	1,948
		2,5	4,41	5,62	90,52	17,82	4,013	20,78	6,45	1,922
		3	5,22	6,65	105,54	20,78	3,985	23,92	7,42	1,897
		4,5	7,48	9,53	144,79	28,50	3,898	31,55	9,75	1,820
		6	9,51	12,11	175,75	34,60	3,809	36,70	11,31	1,741
2"	3/4"	2	4,38	5,58	193,05	25,33	5,882	19,89	5,62	1,888
		2,5	5,41	6,89	235,80	30,94	5,849	23,89	6,75	1,862
		3	6,41	8,17	276,40	36,27	5,816	27,54	7,77	1,836
		4,5	9,27	11,81	385,66	50,61	5,714	36,43	10,27	1,756
		6	11,90	15,16	476,70	62,56	5,608	42,54	11,97	1,675
3"	3/4"	2	5,18	6,59	250,50	32,87	6,163	52,63	10,33	2,825
		2,5	6,41	8,16	307,15	40,31	6,135	63,87	12,52	2,797
		3	7,61	9,70	361,46	47,44	6,106	74,39	14,57	2,770
		4,5	11,07	14,10	510,71	67,02	6,019	101,74	19,88	2,686
		6	14,29	18,21	640,11	84,00	5,929	123,15	24,00	2,601
2"	3/4"	2	5,18	6,59	383,57	37,75	7,626	21,68	5,76	1,813
		2,5	6,41	8,16	469,99	46,26	7,589	26,04	6,92	1,786
		3	7,61	9,70	552,70	54,40	7,550	30,02	7,98	1,760
		4,5	11,07	14,10	778,96	76,67	7,433	39,74	10,57	1,679
		6	14,29	18,21	973,24	95,79	7,311	46,45	12,36	1,597
3"	3/4"	2	5,97	7,61	486,40	47,87	7,994	57,80	10,67	2,756
		2,5	7,40	9,43	597,89	58,85	7,962	70,18	12,94	2,728
		3	8,81	11,22	705,42	69,43	7,929	81,77	15,07	2,700
		4,5	12,86	16,39	1004,64	98,88	7,830	111,97	20,60	2,614
		6	16,69	21,25	1269,66	124,97	7,729	135,74	24,93	2,527
2"	3/4"	2	5,97	7,61	659,20	51,91	9,307	22,99	5,86	1,738
		2,5	7,40	9,43	809,50	63,74	9,264	27,62	7,04	1,711
		3	8,81	11,22	954,10	75,13	9,222	31,83	8,12	1,684
		4,5	12,86	16,39	1354,18	106,63	9,091	42,14	10,77	1,604
		6	16,69	21,25	1704,71	134,23	8,956	49,26	12,61	1,522
3"	3/4"	2	6,77	8,63	820,50	64,61	9,752	61,76	10,90	2,676
		2,5	8,40	10,70	1010,33	79,55	9,716	74,99	13,23	2,647
		3	10,00	12,74	1194,14	94,03	9,680	87,39	15,41	2,619
		4,5	14,66	18,67	1709,98	134,64	9,570	119,72	21,09	2,532
		6	19,08	24,30	2173,46	171,14	9,457	145,20	25,56	2,444

Productos de fabricación local.
Consultar stock.

CANAL "U"

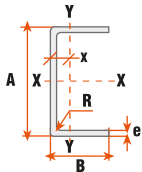
Especificaciones Generales	
6.00, 7.00, 8.00, 9.00 y 10.00 m.	
Lisos de máquina.	
ASTM A36	
Negro	

Dimensiones nominales			Peso teórico	Área	Propiedades							
A	B	e			Eje X-X			Eje Y-Y				
Pulg.	Pulg.	mm	P	A	I	W	X	I	W	Y		
			kgf/m	cm ²	cm ⁴	cm ³	cm	cm ⁴	cm ³	cm		
4"	2"	2	3,09	3,93	64,59	12,71	4,053	10,21	2,75	1,612		
		2,5	3,83	4,87	79,12	15,57	4,029	12,55	3,40	1,605		
		3	4,55	5,80	93,02	18,31	4,005	14,81	4,03	1,598		
		4,5	6,66	8,48	131,12	25,81	3,933	21,10	5,86	1,578		
		6	8,64	11,01	164,01	32,29	3,860	26,70	7,56	1,557		
6"	2"	2	3,88	4,95	166,43	21,84	5,799	11,50	2,89	1,525		
		2,5	4,82	6,14	204,80	26,88	5,773	14,16	3,58	1,518		
		3	5,75	7,32	241,92	31,75	5,747	16,73	4,25	1,511		
		4,5	8,45	10,76	345,88	45,39	5,669	23,96	6,19	1,492		
6"	3"	2	4,68	5,96	223,88	29,38	6,127	35,26	6,27	2,431		
		2,5	5,82	7,41	376,15	36,24	6,103	43,58	7,78	2,424		
		3	6,95	8,85	326,97	42,91	6,079	51,71	9,27	2,418		
		4,5	10,24	13,05	470,93	61,80	6,007	74,98	13,61	2,397		
6"	6"	6	13,43	17,10	602,50	79,69	5,935	96,60	17,76	2,376		
		8"	2"	2	4,68	5,96	332,12	32,69	7,462	12,35	2,98	1,439
				2,5	5,82	7,41	409,77	40,33	7,434	15,22	3,69	1,433
				3	6,95	8,85	485,32	47,77	7,406	17,99	4,38	1,426
4,5	10,24			13,05	699,54	68,85	7,321	25,84	6,39	1,407		
8"	3"	2	5,48	6,98	434,94	42,81	7,894	38,39	6,51	2,345		
		2,5	6,82	8,68	537,67	52,92	7,868	47,48	8,08	2,338		
		3	8,14	10,37	638,04	62,80	7,843	56,38	9,63	2,331		
		4,5	12,04	15,34	925,21	91,06	7,767	81,94	14,15	2,311		
8"	6"	6	15,82	20,15	1191,96	117,32	7,691	105,85	18,50	2,292		
		10"	2"	2	5,48	6,98	574,77	45,26	9,074	12,96	3,04	1,362
				2,5	6,82	8,68	710,41	55,94	9,044	15,97	3,76	1,356
				3	8,14	10,37	842,89	66,37	9,015	18,89	4,47	1,350
4,5	12,04			15,34	1221,59	96,19	8,925	27,17	6,53	1,331		
10"	3"	6	15,82	20,15	1572,70	123,83	8,834	34,76	8,48	1,313		
		10"	3"	2	6,28	8,00	736,07	57,96	9,594	40,72	6,67	2,257
				2,5	7,81	9,95	911,75	71,75	9,568	50,39	8,28	2,250
				3	9,34	11,90	1082,94	85,27	9,541	59,85	9,87	2,243
4,5	13,83			17,62	1577,38	124,20	9,461	87,11	14,52	2,223		
10"	6"	6	18,21	23,20	2041,45	160,45	9,380	112,69	18,99	2,204		

Productos de fabricación local.
 Consultar stock.

Especificaciones Generales

Largo Normal	: 6 m.
Extremos	: Lisos de máquina.
Calidades normales	: ASTM A36
Recubrimiento	: Negro

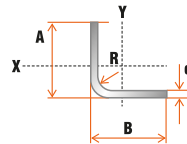

Dimensiones nominales			Peso teórico P	Área A	Propiedades					
A	B	e			Eje X-X e Y-Y				Eje U-U	Eje V-V
mm	mm	mm	kgf/m	cm ²	I	W	i	X=Y	i _{uu}	i _{vv}
20	20	2	0,58	0,73	0,28	0,20	0,62	0,59	0,79	0,37
		3	0,83	1,05	0,38	0,28	0,60	0,64	0,78	0,35
25	25	2	0,73	0,93	0,56	0,32	0,78	0,72	0,99	0,47
		3	1,06	1,35	0,79	0,45	0,76	0,77	0,98	0,45
30	30	2	0,89	1,13	1,00	0,46	0,94	0,84	1,20	0,57
		3	1,30	1,65	1,41	0,67	0,92	0,89	1,18	0,55
		4	1,68	2,14	1,76	0,86	0,91	0,94	1,17	0,53
40	40	2	1,20	1,53	2,44	0,84	1,26	1,09	1,61	0,78
		3	1,77	2,25	3,50	1,22	1,25	1,14	1,59	0,76
		4	2,31	2,94	4,46	1,58	1,23	1,19	1,58	0,74
		5	2,82	3,59	5,31	1,92	1,22	1,24	1,56	0,71
50	50	2	1,52	1,93	4,86	1,33	1,58	1,34	2,01	0,98
		3	2,24	2,85	7,03	1,95	1,57	1,39	2,00	0,96
		4	2,93	3,74	9,04	2,54	1,56	1,44	1,99	0,94
		5	3,60	4,59	10,88	3,10	1,54	1,48	1,97	0,92
65	65	3	2,95	3,75	15,84	3,34	2,05	1,76	2,61	1,27
		4	3,88	4,94	20,54	4,38	2,04	1,81	2,60	1,25
		5	4,78	6,09	24,97	5,38	2,02	1,86	2,58	1,23
		6	5,66	7,21	29,11	6,34	2,01	1,90	2,57	1,21

Productos de fabricación local.
Consultar stock.

TUBOS ESTRUCTURALES

Especificaciones Generales

Largo Normal	:	6 m.
Extremos	:	Lisos de máquina.
Calidades normales	:	ASTM A500 grado A.
Recubrimiento	:	Negro

Cuadrados

Dimensiones nominales		Peso teórico	Propiedades mecánicas		
A	Espesor		Resistencia a la Tracción	Límite de Fluencia	Elongación
mm	mm	Kg/m	n/mm ²	n/mm ²	%
150	3	13,67	381	236	257
150	4,5	20,15	380	280	250
150	6	26,40	381	280	256
200	4,5	27,21	380	280	250
200	6	35,82	380	282	257
250	6	45,24	380	275	255
300	6	54,66	380	281	259

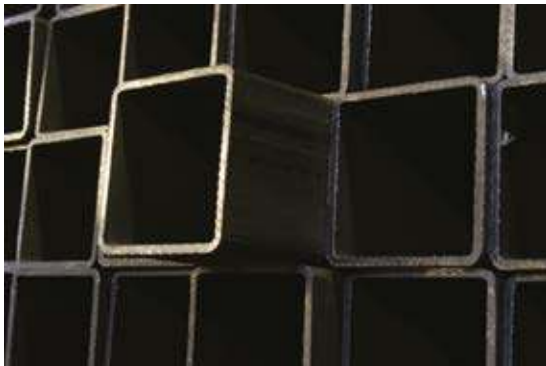
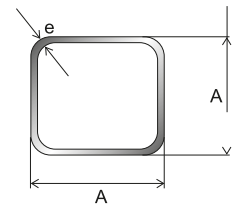

*Consultar stock

TUPEMESA®

☎ Central (51) 637 0000
Línea gratuita 0800 00 267

📍 Planta Lurin Av. Industrial S/n
Zona Industrial Predio Almonte,
Lurín- Lima-Perú

www.tupemesa.com.pe

